Energy Management Box Series



User Manual

EMB-100-4G







EMB-100-WiFi

RENAC

Content

1. Symbols	2
2. Safety and warning	2
3. Introduction	3
3.1 Mechanical design	3
3.2 Technical data	3
4. Mounting	4
4.1 Mounting instruction	4
4.2 EMB-100 overview	4
4.3 Unpacking	5
4.4 EMB-100 installation and commissioning	5
4.4.1 Selecting the installation location	5
4.4.2 Mounting procedure	7
4.4.3 Energy control box communication interface and status indicator	8
4.4.4 Port and wiring instructions	10
4.4.5 CT connection diagram	15
4.4.6 Communication port configuration and export power setting	15
4.4.7 EMB-100 grid connection diagram	16
4.4.8 EMB-100-WiFi settings	17
4.4.9 EMB-100-4G settings	17
4.4.10 EMB-100-LAN settings	18
5. Disposal	18

1. Symbols

	Caution! Failure to observe a warning indicated in this manual may result in minor or moderate injury!
	Danger of high voltage and electric shock!
	Product should not be disposed as normal household waste.
	Keep Dry. The package/product must be protected from excessive humidity and must accordingly be stored under cover.
	Components of the product can be recycled.
	This side up. The package must always be transported, handled and stored in such a way that the arrows always point upwards.
	The package/product should be handled carefully and never be tipped over or slung.

2. Safety and warning

EMB-100 of Renac Power Technologies Co., Ltd. (hereinafter referred to as Renac) has been designed and tested strictly according to international safety regulations. As for electrical and electric equipment, safety regulations shall be followed during installation and maintenance. Improper operation may bring severe damage to the operator, the third party, and other properties. Installation maintenance of EMB-100 must be performed by qualified personnel in compliance with local electrical standards, regulations and the requirements of local power authorities.

- To avoid electric shock, make sure the connection between EMB-100 and the AC output of the inverter and Grid is disconnected before performing any installation or maintenance.
- When in operation, users should not touch any of the electrical parts of EMB-100, like internal components and cables, to avoid electric shock.
- All electrical installations must comply with local electrical standards and obtain permission from local power authorities before EMB-100 can be connected to the grid by professionals.
- Before replacing any internal components of EMB-100, the connection between the inverter and EMB-100, the power grid, and EMB-100 must be disconnected, and the newly replaced components must meet the requirements of EMB-100. Otherwise, RENAC will not assume responsibility and quality assurance for the personal harm.
- Make sure that the AC input voltage and input current match the rated voltage and current of EMB-100. Otherwise, the

components will be damaged or cannot work properly, and RENAC will not assume responsibility and quality assurance for this case.

- There are lightning protection modules inside. Make sure to connect the internal PE with the ground when installing EMB-100.
- When in operation, do not plug or unplug cables of EMB-100.
- EMB-100 must be installed out of reach of children.
- EMB-100 supports the three-phase, four-wire grid structure only.
- EMB-100 has a timed reboot function and is factory defaulted to reboot at 2 am. If you need to change the time, please contact the manufacturer.

3. Introduction

3.1 Mechanical design

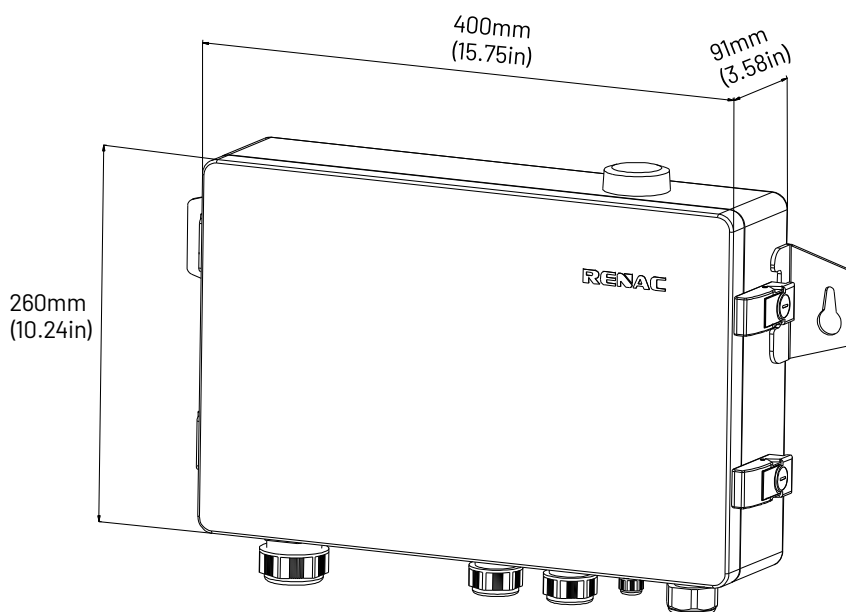

Figure 3-1

3.2 Technical data

Model	EMB-100-4G	EMB-100-WiFi
AC Input Data		
Grid Connection	3L / N / PE	
Input Voltage Range [V]	Phase Voltage: 60 ~ 275 / Line Voltage: 100 ~ 480	
Grid Frequency [Hz]	50 / 60	
Communication		
RS485 Interface	7+1 (Meter fixed occupation of the first interface)	
Ethernet	2	
Max inverters per 485 Channel	16	
Communication Distance [m]	RS485 : 500	
CT Data		

Model	EMB-100-4G	EMB-100-WiFi
Max. Input Current (CT second side)[A]	5	
Accuracy [%]	0.5	
General Data		
Dimensions [W*H*D]	400mm*260mm*91mm	
Weight [kg]	5.7	
Operating Temperature Range [°C]	-25 ~ 60	
Operation Humidity	0 ~ 100%	
Installation Type	Wall-mounted	
Operation Altitude [m]	≤ 2000	
Enclosure	IP65	

4. Mounting

4.1 Mounting instruction

- EMB-100 must be installed where there is no significant shaking, shock vibration, and no direct rain or snow.
- EMB-100 shall be installed at eye level for easy operation and maintenance.
- EMB-100 should not be installed near inflammable and explosive items.
- EMB-100 shall be installed at a location free from explosive hazardous media and free from gas and dust sufficient to corrode metals and destroy insulation.
- EMB-100 parameters and warning signs must be clearly visible after installation.
- EMB-100 should be installed without sunshine, rain, and snow.

4.2 EMB-100 overview

elevation view:

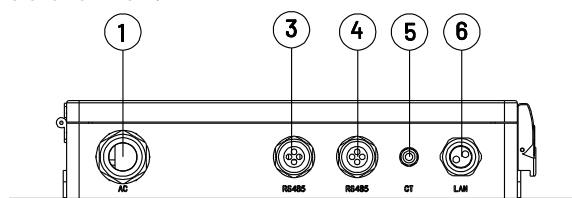

top view:

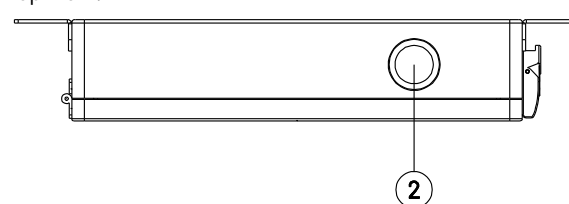

Figure 4-1

1	AC voltage input port (L1/L2/L3/N/PE)
2	4G / WiFi antenna output port (Antenna)
3	Communication port (RS485)
4	Communication port (RS485)
5	AC voltage output port (external CT)
6	LAN network port (NET)

Note: EMB-100 supports the three-phase, four-wire grid structure only, which means the neutral wire is necessary.

4.3 Unpacking

Check the delivery for completeness. Contact your dealer at once if anything is missing or damage.

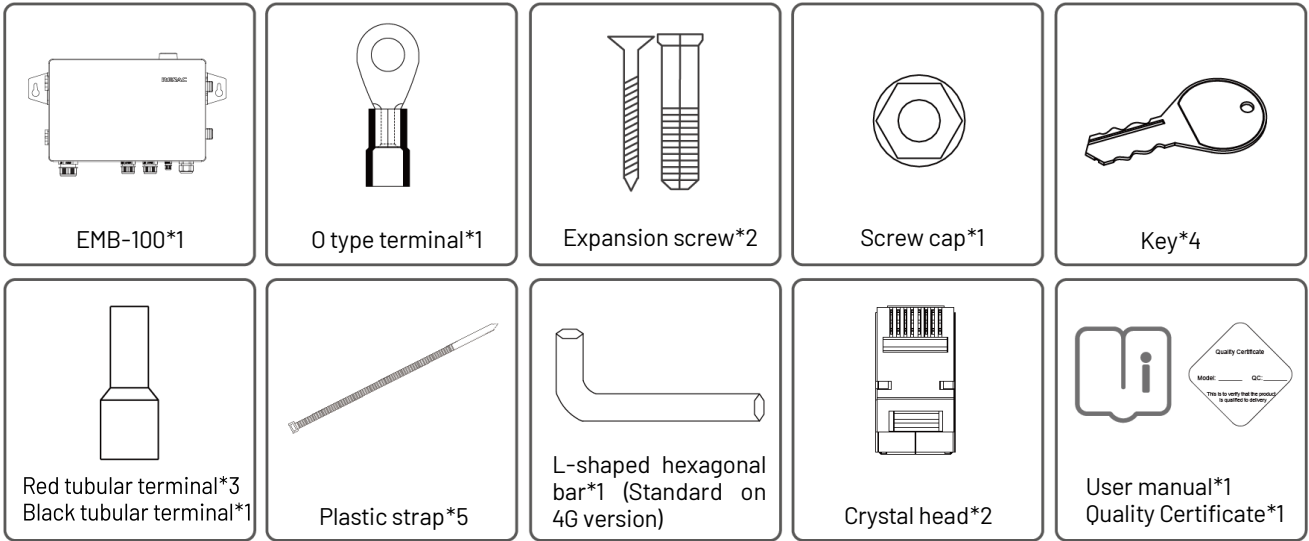

Figure 4-2 Product and accessories

4.4 EMB-100 installation and commissioning

4.4.1 Selecting the installation location

The following must be considered when selecting the best location for an EMB-100:

- The mount and installation method must be appropriate for the EMB-100's weight and dimensions.
- Install on a sturdy surface.
- The installation location must be well ventilated.
- EMB-100 can be placed horizontally or installed vertically.
- The EMB-100 must be installed vertically or with a backward tilt of less than 15°. No sideways tilt is allowed. The connection area must point downwards. Refer to Figure 4-3.

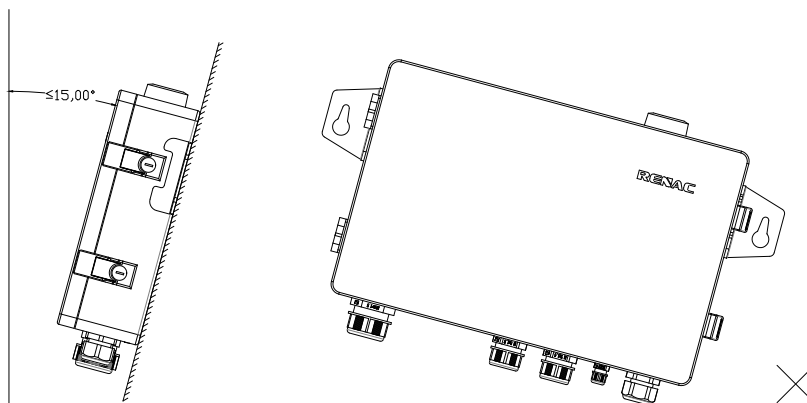

Figure 4-3

- To allow the dissipation of heat and for the convenience of dismantling, clearances around the EMB-100 must be no less than the values refer to Figure 4-4.

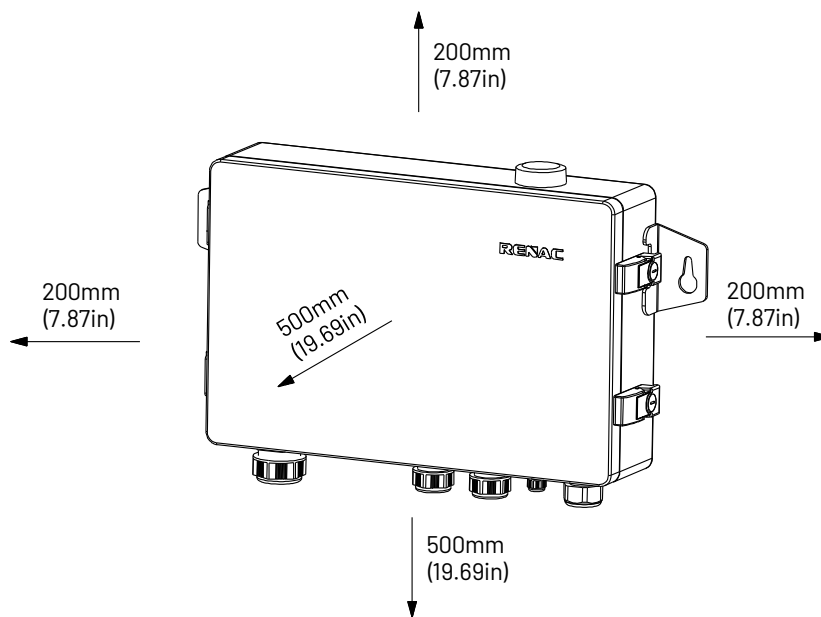

Figure 4-4 Minimum clearance required

- EMB-100 can be placed horizontally to work, as shown in Figure 4-5.

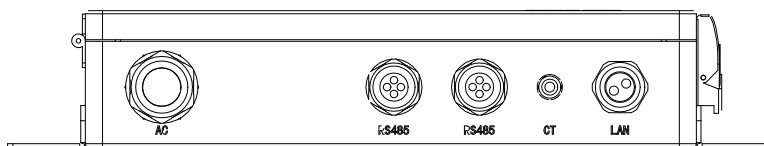

Figure 4-5

- EMB-100 should be placed in a fixed place indoors / outdoors, as shown in Figure 4-6.

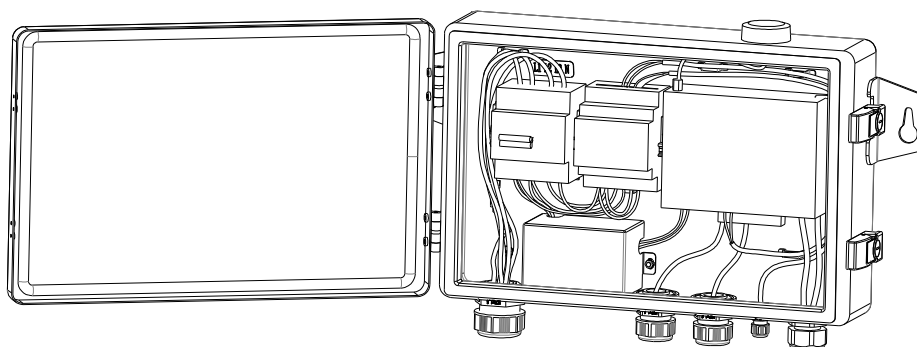

Figure 4-6

4.4.2 Mounting procedure

(1) After unpacking the EMB-100, open the cabinet door and remove three pieces of EPE pearl cotton and a piece of paper tape.

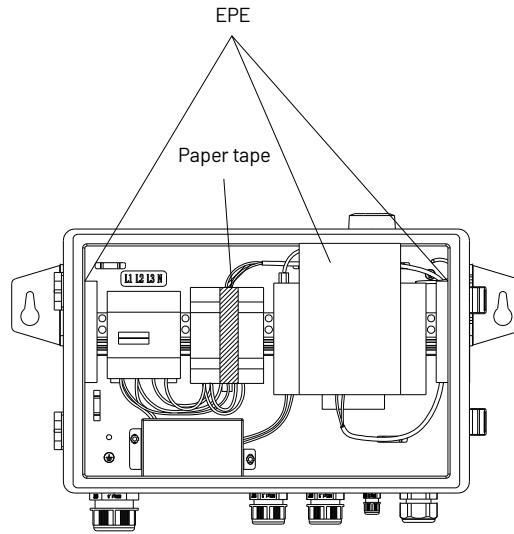

Figure 4-7

(2) If you purchase EMB-100-4G, please purchase a suitable 4G card to insert in the SIM cardholder of the control box. You need to insert an L-shaped hexagonal bar with a diameter of no more than 2.4mm into the round hole next to the cardholder to make the card holder pop out, then put the 4G card in place, and then put the card holder back into the control box. If you purchase the EMB-100-WiFi, please ignore this action.

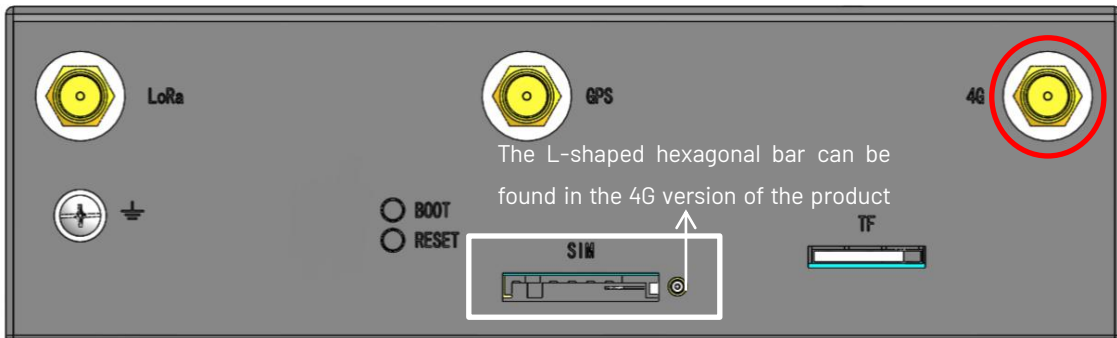

Figure 4-8 Energy control box top view

(3) Check the 4G/WiFi antenna is installed. If it is not installed, the antenna needs to be connected, as shown in the red circle circled above.

(4) Drill holes on the wall, $\Phi 11$ mm in diameter and 50mm deep. Refer to Figure 4-9.

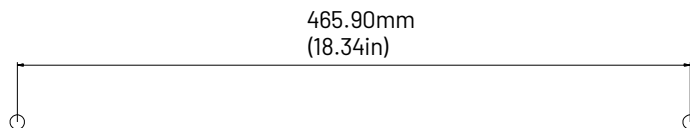

Figure 4-9

(5) Fix the wall mounting EMB-100 on the wall with expansion bolts in accessory bag. Refer to Figure 4-10.

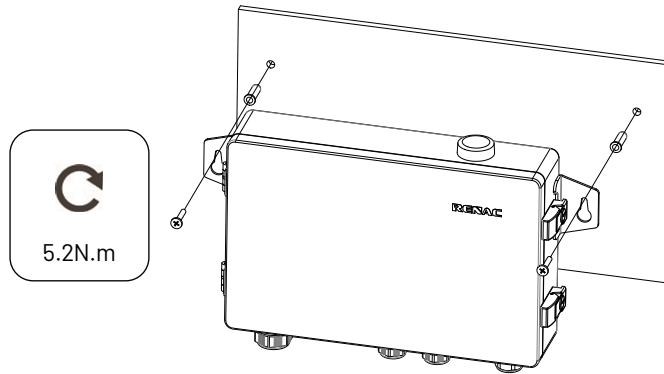

Figure 4-10 Wall mounting



NOTE!

- EPE pearl cotton and paper tape are protective auxiliary materials used in the transportation process.
- It is recommended to install in the line with corresponding lightning protection.

4.4.3 Energy control box communication interface and status indicator

The Energy Control Box is the control core of the EMB-100 and its communication interfaces are described as shown below.

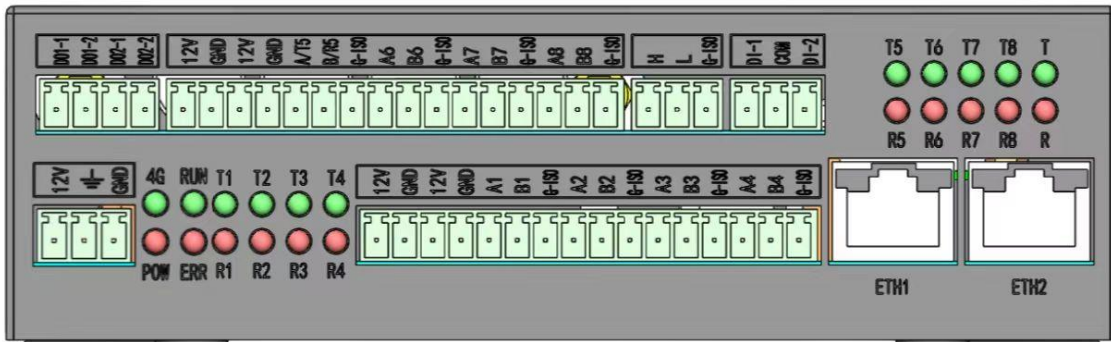

Figure 4-11

Pin	Description	Function	Pin	Description	Function
A1	RS485_1 Data+	Used to communicate with the meter.	A/T5	RS485_5 Data+ /RS232_T	Used to communicate with the inverters.
B1	RS485_1 Data-		B/R5	RS485_5 Data- /RS232_R	
A2	RS485_2 Data+	Used to communicate with the inverters.	A6	RS485_6 Data+	Used to communicate with the inverters.
B2	RS485_2 Data-		B6	RS485_6 Data-	
A3	RS485_3 Data+	Used to communicate with the inverters.	A7	RS485_7 Data+	Used to communicate with the inverters.
B3	RS485_3 Data-		B7	RS485_7 Data-	
A4	RS485_4 Data+	Used to communicate with the inverters.	A8	RS485_8 Data+	Used to communicate with the inverters.
B4	RS485_4 Data-		B8	RS485_8 Data-	

The status indicator can indicate the status of RS485/RS232 transmitting and receiving.

Indicator	Status	Description
T1~T8	Green, Flashing	Signal sent successfully.
R1~R8	Red, Flashing	Signal received successfully.
POW	Red, Steady	Power-on.
	Off	Power-off.
ERR	Red, Steady	System errors.
	Off	System is normal.
4G	Green, Steady	Communication is normal.
	Green, Fast flashing(125ms)	Data is being transmitted.
	Green, Slow flashing(200ms)	Idle.
	Green, Slow flashing(1800ms)	Looking to network.
RUN	Green, Steady	Program is being written.
	Green, Slow flashing(1S)	Program writing is complete.
	Green, Flashing	The system startup is complete, and the status indicator serves as a heartbeat light.
	Off	The system is starting up.



NOTE!

ETH1 is a fixed port, and its IP address and other parameter information cannot be modified. Its default IP address is 192.168.1.232. ETH2 port is a user-defined port, and its configuration parameters can be modified through the configuration page.

485 communication cable for the energy control box:

It is recommended to use shielded twisted pair cables with conductor area 0.2 mm² for 485 communication cables.

No.	Function
1	RS485 +
2	RS485 -

Screw

4.4.4 Port and wiring instructions

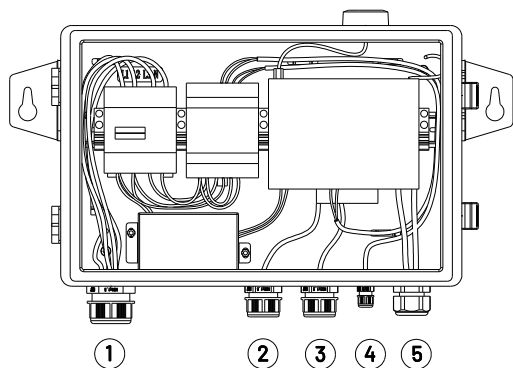

Figure 4-12

No.	Description
1	Voltage Input Port (L1/L2/L3/N/PE)
2	Communication Port
3	Communication Port
4	Current Input Port (three sets of CT)
5	LAN Network port

① Voltage Input Port (L1/L2/L3/N/PE)

Input phase voltage range: AC60V-AC280V; Input line voltage range: AC100V-AC480V; AC Frequency: 50/60Hz;



WARNING!

Misconnecting the N wire may cause damage to the meter.

AC connection:

Use wire crimper to press

No.	Description	Content
A	Wire Diameter	No more than 25 mm
B	Cross Sectional Area of Copper Wire	Recommend: 4-6 mm ²
C	Wire Length	About 45 mm
D	Length of Bare Copper Wire	About 12mm(10mm for PE)

② & ③ Communication Port

The system supports up to 112 inverters. Each interface supports up to sixteen inverters. Please distribute them equally to each COM port.



NOTE!

The RS485 communication port on the Renac R3-50K and the following models is an RJ45 port, which is suitable for the first connection method. The RS485 communication port on models above Renac R3-70K is a 4P terminal, which is suitable for the second connection method.

Multi-inverter communication system

Connection mode 1: When the RS485 port on the inverter is an RJ45 port, a dual 485 adapter is required. For detailed port definitions, refer to the inverter's user manual. The dual 485 adapter is sold separately.

Renac R3-50K and the following models communication connection:

Dual 485 adapter:

Pin	1	2	3	4	5	6	7	8
Function	RS485A	RS485B	GND	/	/	/	/	/

Connection Steps:

- 1) Remove the crystal head from the outside end of the dual 485 adapter connected to the first inverter. Mark the RS485A and RS485B wires as described above.
- 2) Connect the RS485A and RS485B wires of the first group of first inverters to "A2, B2" of the energy control box, the twisted pair end of the second group of first inverters to "A3, B3" of the energy control box, and so on up to a maximum of 7 groups.
- 3) Connect the dual 485 adapter to the communication port of the Inverter 1.
- 4) Connect the other end of the dual 485 adapter to the communication port of Inverter 2, and so on, as shown in Figure 4-13.

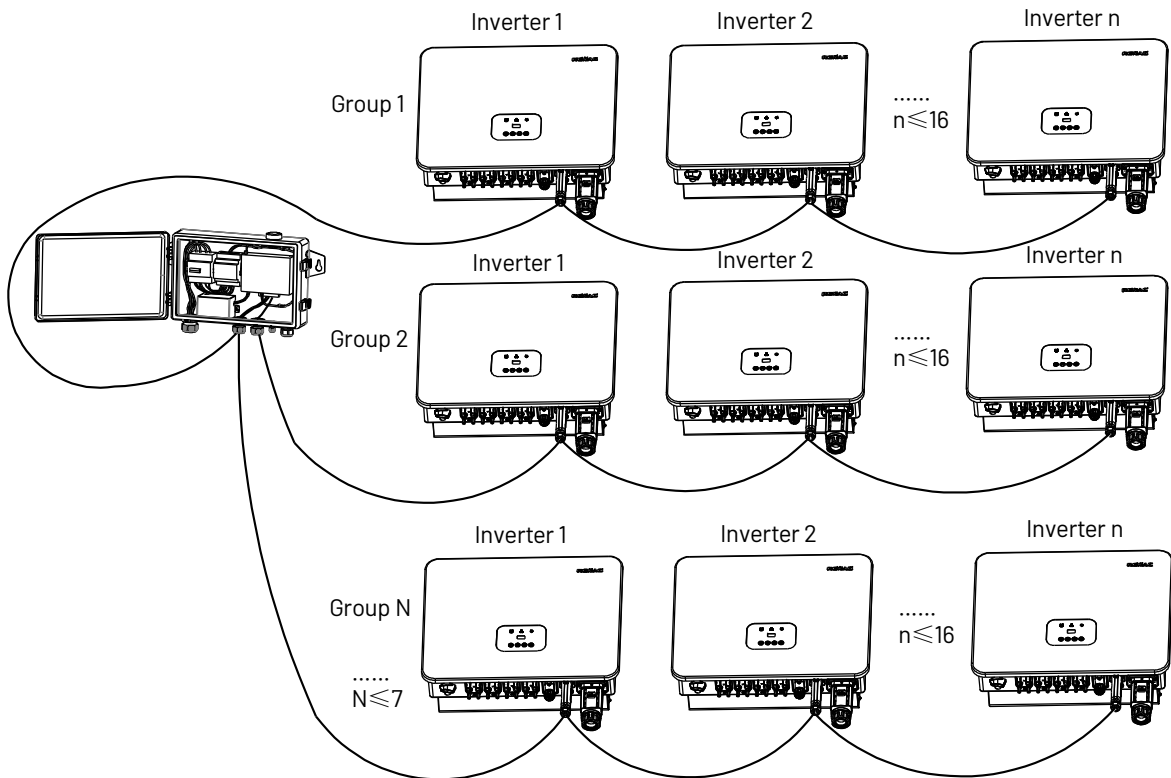
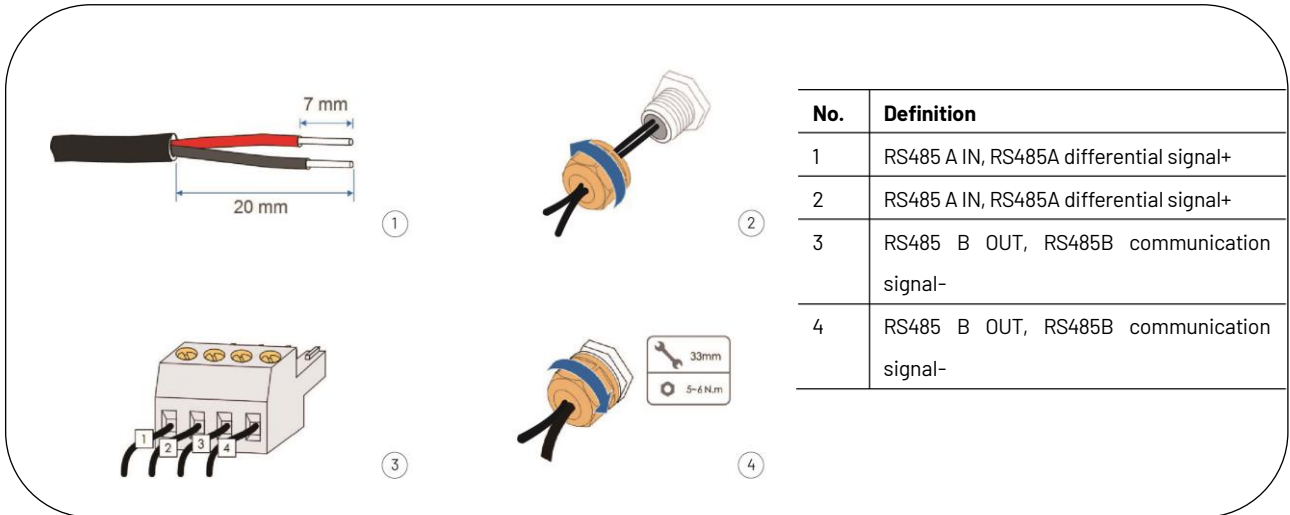

Figure 4-13

Connection mode 2: When the RS485 port in the inverter as well as the terminals equipped for the wiring board. For detailed port definitions, refer to the inverter's user manual.

Renac R3-70K above models communication connection:



Connection Steps:

- 1) Connect the twisted pair end of the first group of first inverters to "A2, B2" of the energy control box, the twisted pair end of the second group of first inverters to "A3, B3" of the energy control box, and so on up to a maximum of 7 groups.
- 2) Connect the other end of twisted pair the communication port of the Inverter 1. Note the port definitions; see the inverter's user manual for details.
- 3) In case of multiple inverters, all the inverters can be connected via RS485 cables in the daisy chain manner, as shown in Figure 4-14.

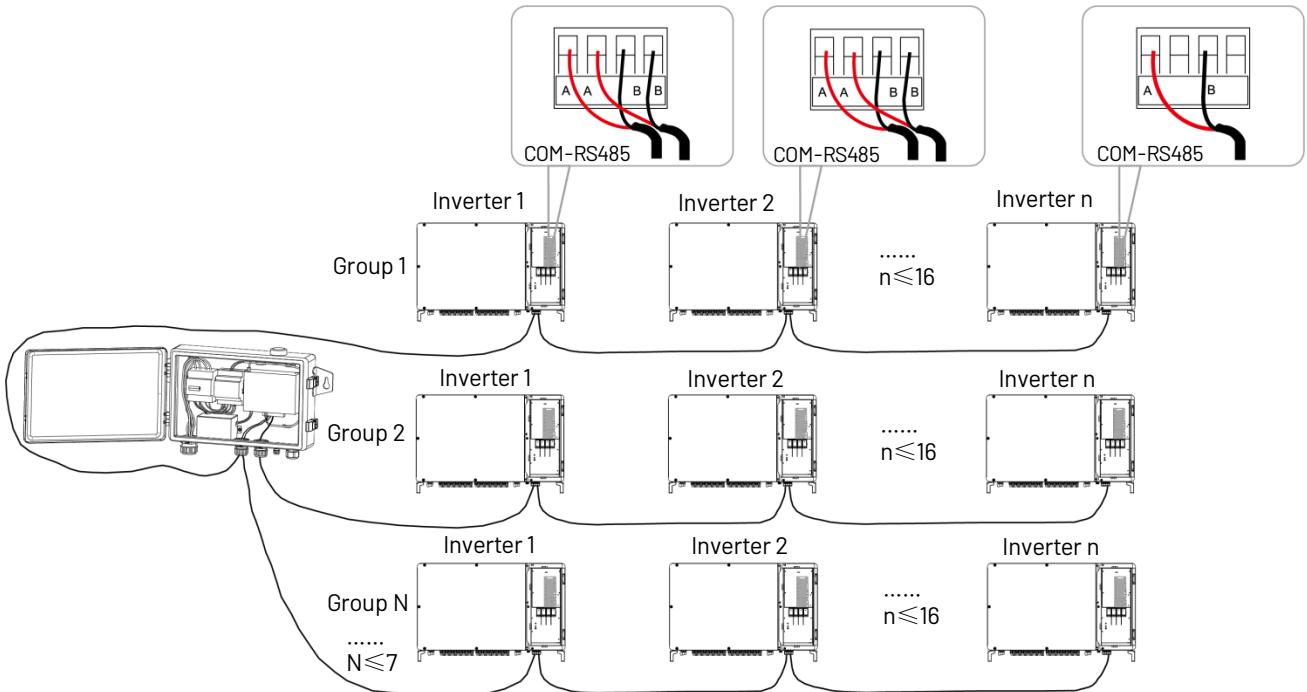

Figure 4-14

④ Current Input Port (three sets of CT)

Connect three sets of external CTs to port four at the location shown in Figure 4-11.

Recommended CT

According to the external current range, Renac recommends the following specifications, for reference only.

No.	Model	Primary Current	Second Current	Perforation Size	Class
1	Eastron-ESCT-T36-5	300A	5A	34.9mm*36.9mm	0.5
2	Eastron-ESCT-T36-5	600A	5A	34.9mm*36.9mm	0.5
3	Eastron-ESCT-B58	600A	5A	50mm*80mm	0.5
4	Eastron-ESCT-B812	1200A	5A	80mm*120mm	0.5
5	Eastron-ESCT-B816	2000A	5A	80mm*160mm	0.5
6	Eastron-ESCT-B816	4000A	5A	80mm*160mm	0.5
7	Eastron-ESCT-B816	6000A	5A	80mm*160mm	0.5

CT connection:

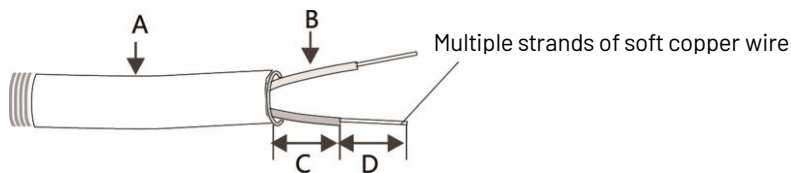

No.	Description	Content
A	Wire Diameter	No more than 6 mm
B	Cross Sectional Area of Copper Wire	Recommend: 1-2 mm ²
C	Wire Length	About 45 mm
D	Length of Bare Copper Wire	About 5mm

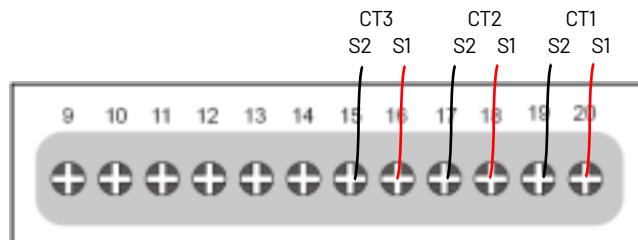
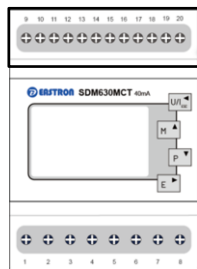
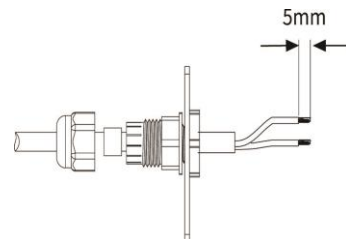

Connect CT1 to "S1, S2" on the right, CT2 to "S1, S2" in the middle, and CT3 to "S1, S2" on the left, as shown above. The CT direction must be facing to the load.

If you do not buy the CT model as recommended by our company, you need to set the CT value on the Renac SEC after everything is commissioned. You need to configure the CT value in the Renac SEC. Enter the statistics interface of any inverter connected to the EMB-100, click the upper right corner to enter the device list, and select "Meter". Then click on the top left corner to set the CT value.

Note: CT Value = Primary Current / Second Current. For example, select Eastron-ESCT-T36-5; the CT value is 60.

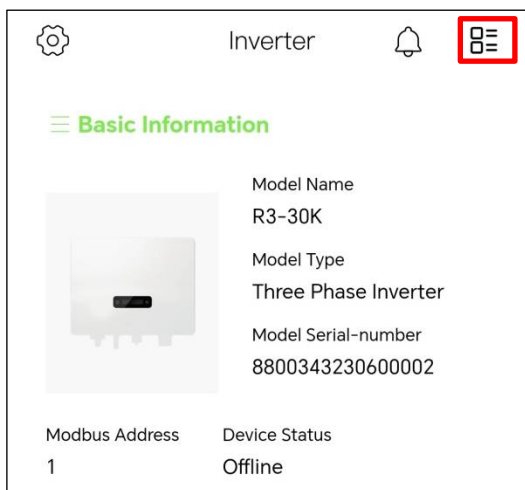

Figure 4-15

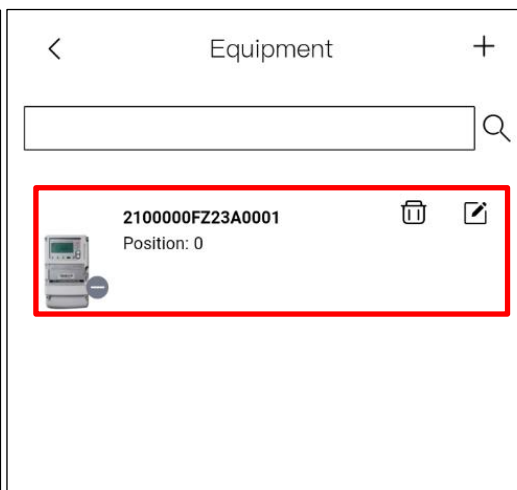

Figure 4-16

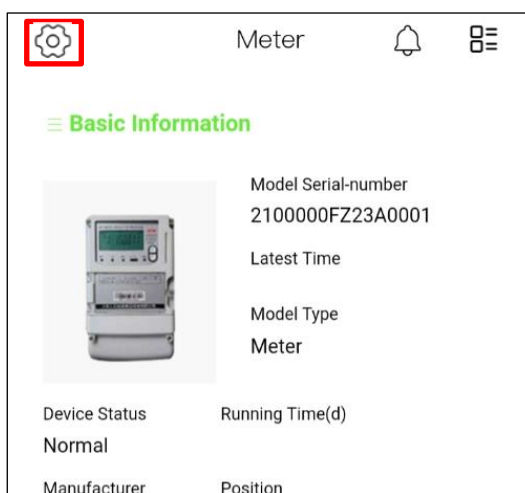

Figure 4-17



Figure 4-18

⑤ LAN Network port

EMB-100 uses this port when accessing a network cable. The access point is shown in the "ETH1" position in the control box. It is recommended to use network cables above the Super Five Type. After wiring, use the fire-proof mud to seal the port to ensure its protective performance.

4.4.5 CT connection diagram

Inverters have the function of anti-reverse current, which can control the power exported to the grid by connecting an intelligent electricity meter. The arrow on the CT must point to the loads.

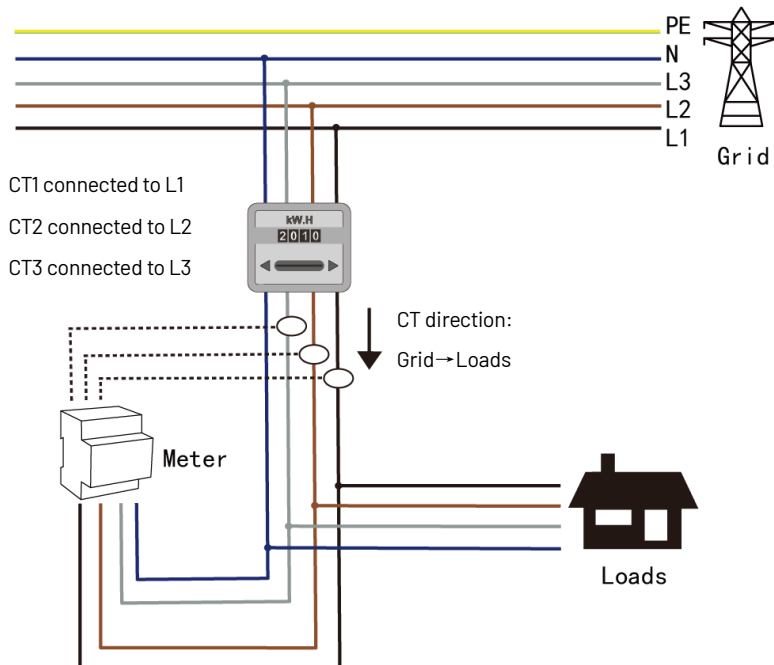

Figure 4-19

4.4.6 Communication port configuration and export power setting

- 1) You need to set the RS485 address of the inverter connected to RS485 port of EMB-100. The address should be 1~16 for each port. The menu operation can refer to the inverter user manual.
- 2) You need to collect the inverter information corresponding to the 485 communication port and contact the technical service of Renac for configuration.
- 3) You need to configure the export limit power in the Renac SEC. Enter any inverter setting interface connected to the EMB-100 to set the export limit power. Click the settings icon in the upper left corner to enter the settings screen. You will need to enter your account password again before entering the settings screen for the first time.
- 4) Set up the export limit power, and click 'Save'. Refer to Figure 4-21. Add the inverter operation in the Renac SEC can refer to the ST-WIFI-G2 user manual.

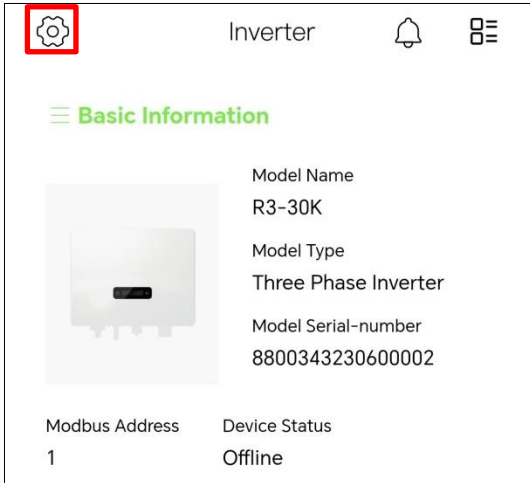

Figure 4-20

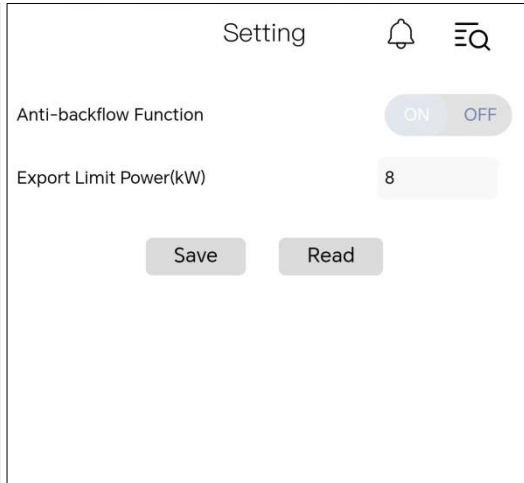

Figure 4-21

4.4.7 EMB-100 grid connection diagram

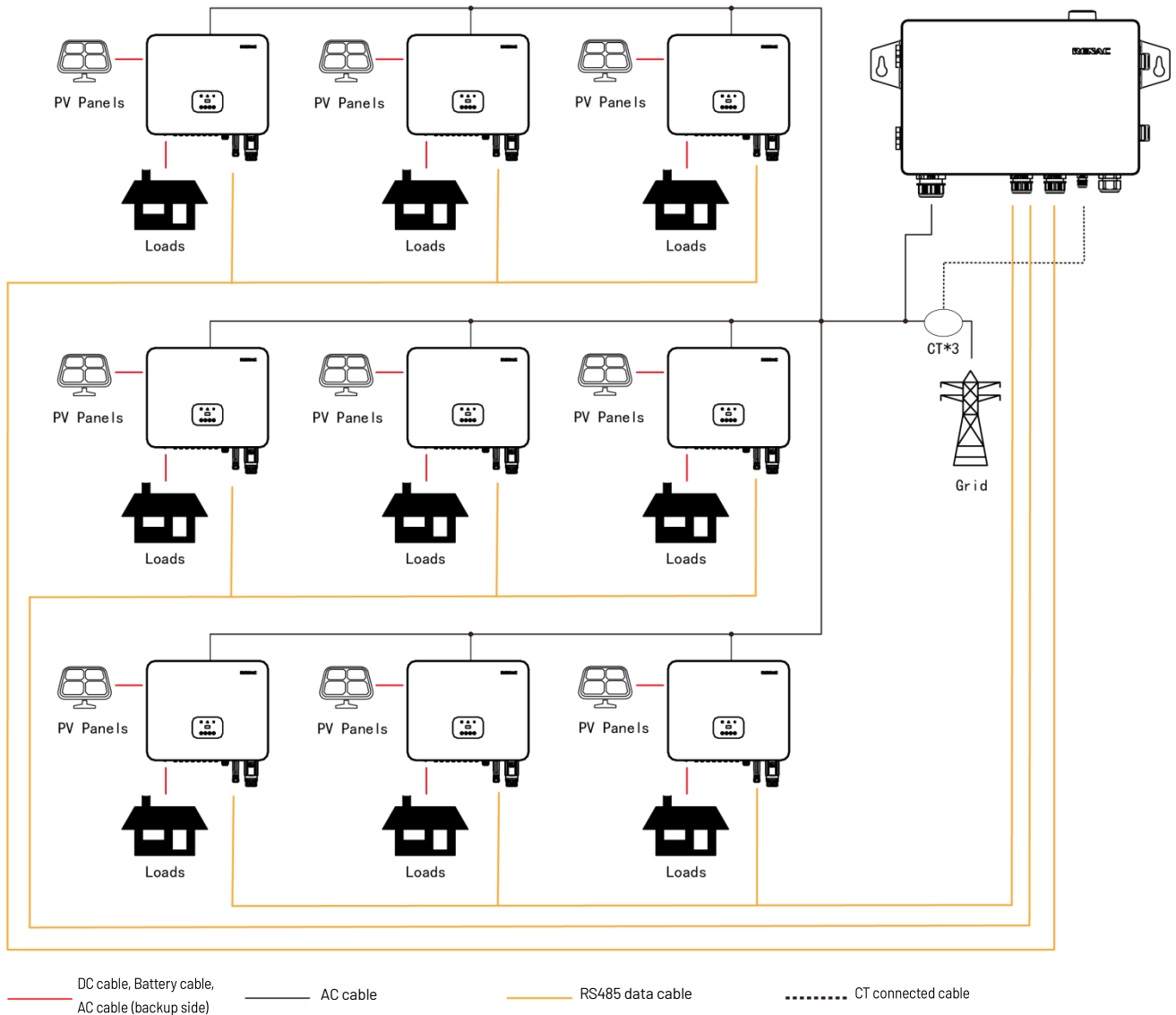

Figure 4-22 Grid connection diagram

- The system supports up to 112 inverters, please distribute them equally to each COM port.
- No separate Smart Meter is required in the inverter paralleling system along with EMB-100 deployed. This solution is only applicable to the paralleling of on-grid side not to back-up side. The firmware version of EMB-100 designated for inverter paralleling application should be 01 or newer.

4.4.8 EMB-100-WiFi settings

1. Set the computer's client segment to 192.168.1; the last set of digits in the IP segment cannot be 232, for example, 192.168.1.11.
2. Connect the Ethernet cable and the ETH1 interface of the EMB-100 together.

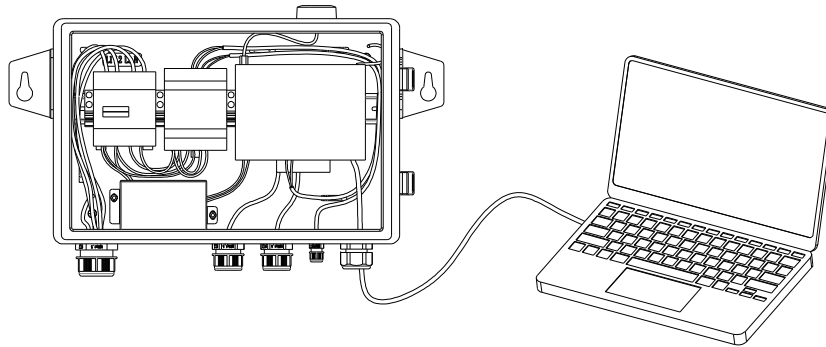

Figure 4-23

3. Enter the website address <http://192.168.1.232> and jump out of the setting interface.
4. WiFi Config: Enter SSID and Password, and click 'Save'.

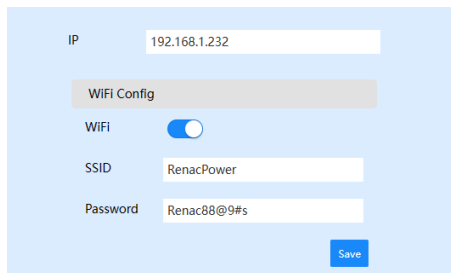

Figure 4-24

4.4.9 EMB-100-4G settings

1. Enter website address <http://192.168.1.232>.
2. 4G APN (Access Point Name) Config: Enter the Access Point Name address, username, and password for the current installation area, and click 'Save'. Items marked with * are required. The APN must match the operator of the inserted 4G card.

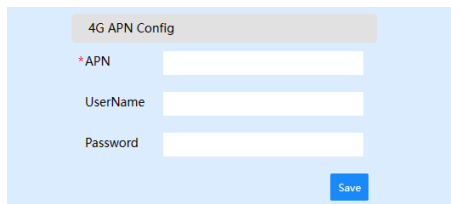

Figure 4-25

4.4.10 EMB-100-LAN settings

1. Enter website address <http://192.168.1.232>.
2. Modifying IP parameters in the above webpage defaults to modifying the ETH2 interface.

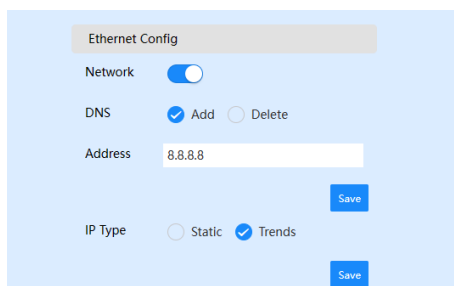

Figure 4-26

5. Disposal

When the EMB-100 or other related components need to be disposed of, have it carried out according to local waste handling regulations. Please be sure to deliver wasted inverters and packing materials to a certain site where the relevant department can dispose of and recycle them.



www.renacpower.com

422-00175-03

SMART ENERGY FOR BETTER LIFE

RENAC

RENAC POWER TECHNOLOGY CO., LTD.

Block C-12, No. 20 Datong Road, Comprehensive Bonded Zone, Suzhou Hi-Tech District, Suzhou, China

Tel: +86-0512-66677278

info@renacpower.com

www.renacpower.com